

MODEL 506

HEAVY DUTY INCLINING CONVEYOR HEAVY SHAFT M505

This units deep frame, 3" high cleats, 6" high Side rails and large drive pulley are designed to move larger products easily and efficiently up inclines. This sturdy, solid conveyor is built to last and withstand heavy usage.

Widths: 12" - 48"

Lengths: 5' - 25' (6" Increments)

Standard Length is 5', Two Piece Bolt Together

Standard Speed: 60 FPM

Standard Motor: 3/4 HP 230/460/3/60 TEFC

Standard Drive: Top Mount, Right Side

Standard Belt: Black PVC 120 with 3" high cleats on 12" centers, Clipper Lacing

Drive Pulley: 8" Dia Crown Face Rubber Lagged x 1-11/16"

Infeed Pulley: 8" Dia Crown Face Take Up x 1-7/16"

Frame: 13" Deep x 10 Gauge

Bearings: Grease Sealed

Others: Base unit includes 6" high Side rails and Bottom Pan

BELT WIDTH:	12"	18"	24"	30"	36"	48"
FRAME WIDTH:	15"	21 1/2"	28"	34"	40"	52"

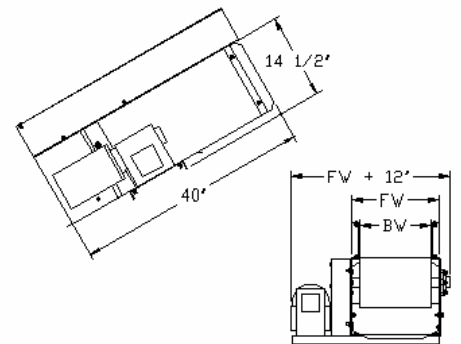

SIDE MOUNT DRIVE

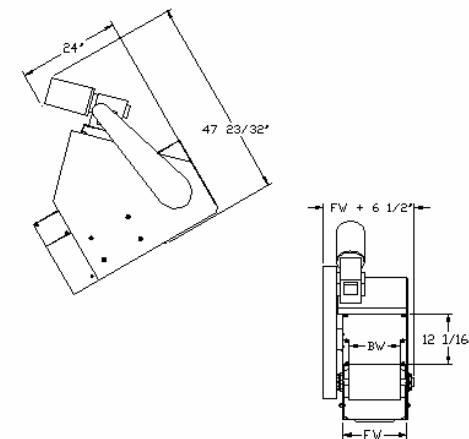

TOP MOUNT DRIVE

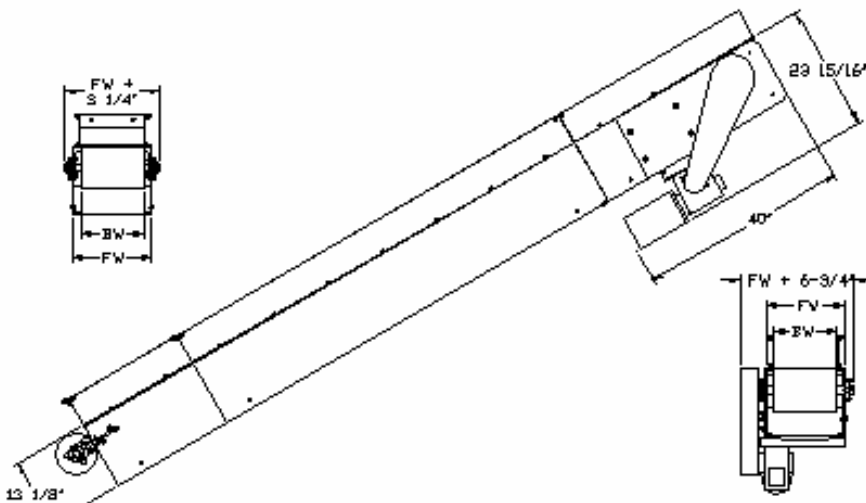

BOTTOM DRIVE